

# FOLDALITE<sup>®</sup> 32

Full-body UV Phototherapy System



 **NATIONAL  
BIOLOGICAL**

**S.E.E. the Light!**  
**SAFE, EFFECTIVE & ECONOMICAL**

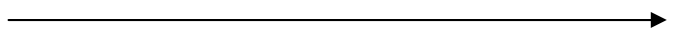

# FOLDALITE<sup>®</sup> 32

Optimum Phototherapy  
Performance in an  
Ultra-Thin Design

The **FOLDALITE<sup>®</sup> 32** represents the pinnacle of phototherapy technology. Designed to treat the entire body in a single session, the **FOLDALITE<sup>®</sup> 32** features simple operation and quick treatment times.



The **PhotoSense<sup>®</sup> Exposure Control** lets you preset a maximum exposure time for each session to minimize the chance for overexposure.

A safety key lock on the ON/OFF switch prevents unauthorized use. Watchdog circuitry shuts down device if it senses a potential malfunction.

Folds Closed  
to 23 cm (9")

Available in  
Narrow Band and  
other lamp types.



Comfort control ventilation ensures patient comfort

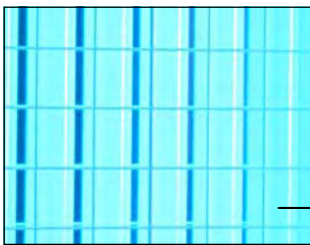

Safety screens allow for maximum energy output and snap out for easy lamp replacement.

Easily adjust to different body sizes, yet folds to 229mm (9") for storage. Doors move and re-position effortlessly. Adjustable wheels designed for any floor surface. Can be installed in room corners.



0.5 m<sup>2</sup> (5.4 square feet) of treatment area



National Biological maintains a full line of phototherapy accessories in stock at all times. Included are UVA and UVB measuring devices, high output UVA and UVB lamps, glasses and goggles for eye protection.



Includes UVB measuring device

# FOLDALITE® 32

## Phototherapy System

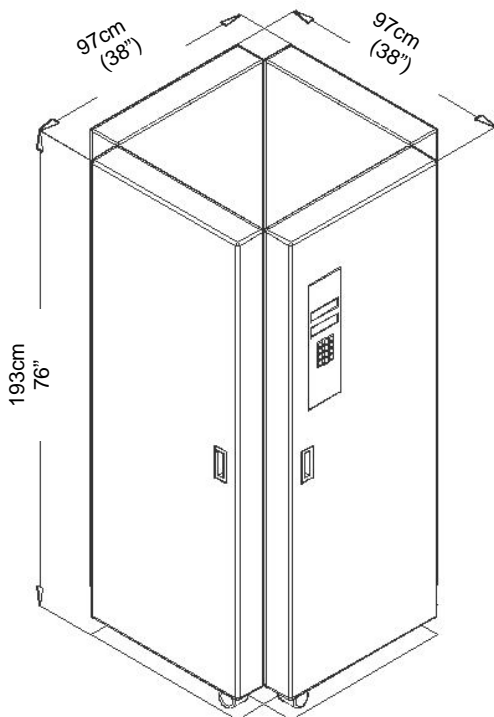
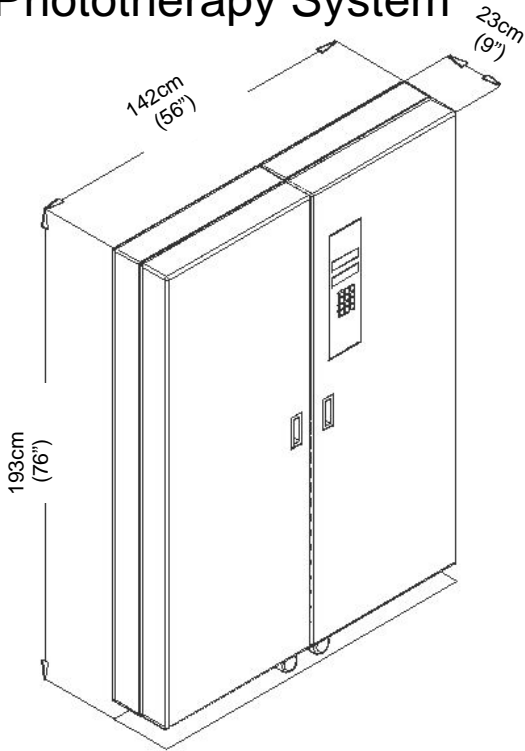

### Specifications

#### Electrical Rating

- 120/240 VAC hard wired to disconnect box
- 15 amps per leg

#### Dimensions (depth x height x width)

- Open: 97 x 193 x 97 cm (38" x 76" x 38")
- Closed: 23 x 193 x 142 cm (9" x 76" x 56")

#### Lamps

- 32 High output 311nm Narrowband UVB lamps TL100/W FS72  
*National Biological uses only Philips TL Brand Narrowband UVB Lamps*
- Also available: UVA, UVA-1

#### Warranty

- All parts (excluding lamps) carry a 3-year, **free** replacement warranty from the date of installation.
- Extended warranties also available.
- Lamps warranted for 90 days.



Quality System  
Certified to  
ISO 13485



Adjusts to virtually any size body,  
small or large



23700 Mercantile Road  
Beachwood, OH 44122 USA  
Phone: 00 1 216-831-0600  
Fax: 00 1 216-765-0271

Email: [info@PhototherapyExperts.com](mailto:info@PhototherapyExperts.com)  
Web: [www.PhototherapyExperts.com](http://www.PhototherapyExperts.com)