

FOLDALITE® 32

Phototherapy System

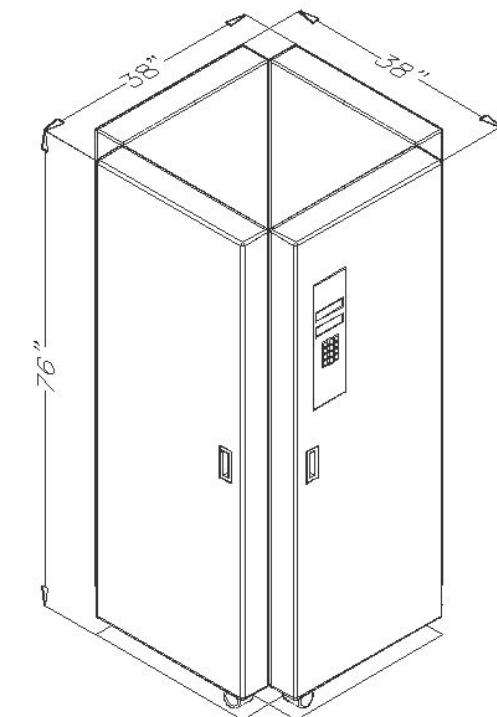
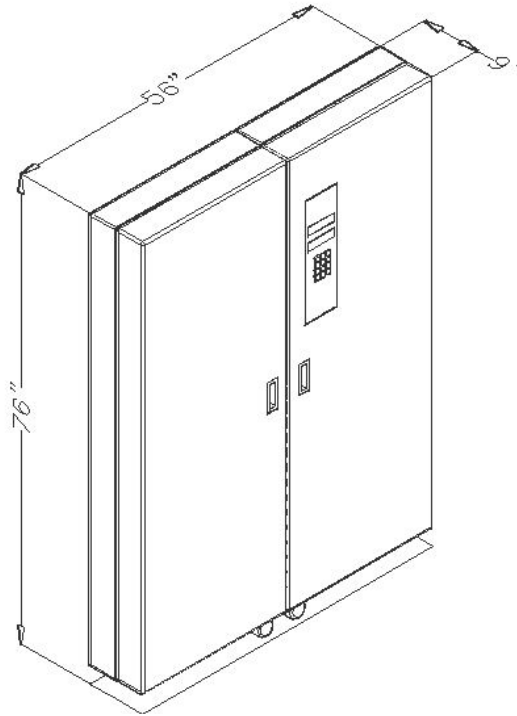

Specifications

Electrical Rating

- 120/240 VAC hard wired to disconnect box
- 15 amps per leg

Dimensions

- Open: 38"D x 76" H x 38" W
- Closed: 9"D x 76" H x 56" W

Lamp Configurations

- 32 High output TL100/W FS72 311nm Narrowband UVB lamps
- Also available: UVA, UVA-1
- National Biological uses only new Philips TL Brand Narrowband UVB Lamps

Warranty

- All parts (excluding lamps) carry a 3-year, **free** replacement warranty from the date of installation. Extended warranties also available.
- Lamps warranted for 90 days.



Adjusts to virtually any size body, small or large



23700 Mercantile Road
Beachwood, OH 44122
(800) 338-5045 Fax: (216) 765-0271
Email: info@PhototherapyExperts.com
Web: www.PhototherapyExperts.com

F321109

FOLDALITE® 32

Full-body UV Phototherapy System



S.E.E. the Light!
Safe, Effective & Economical

FOLDALITE® 32

Optimum Phototherapy Performance in an Ultra-Thin Design

The **FOLDALITE® 32** represents the pinnacle of phototherapy technology. Designed to treat the entire body in a single session, the **FOLDALITE® 32** features simple operation and quick treatment times.



The **PhotoSense® Exposure Control** lets you preset a maximum exposure time for each session to minimize the chance for overexposure.

A safety key lock on the ON/OFF switch prevents unauthorized use. Watchdog circuitry shuts down device if it senses a potential malfunction.

Available in Narrow Band and other lamp types.

Folds Closed to 9"



Comfort control ventilation ensures patient comfort

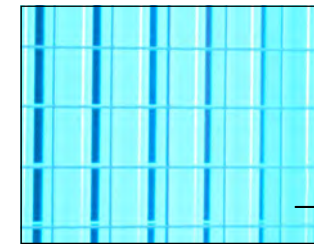

Safety screens allow for maximum energy output and snap out for easy lamp replacement.

Easily folds to 9" to adjust to different body sizes and storage possibilities. Doors move and re-position effortlessly. Adjustable wheels designed for any floor surface. Can be installed in room corners.



5.4 square feet of treatment area, 35% more than other folding units



National Biological maintains a full line of phototherapy accessories in stock at all times. Included are UVA and UVB measuring devices, high output UVA and UVB lamps, glasses and goggles for eye protection.



Includes UVB measuring device