

Hand/Foot II™

High Output UV Phototherapy Device



Available with 311 Narrowband UVB Lamps

- ◆ High Output Device for Quick and Effective Treatments
- ◆ Ideal for office or in-home use
- ◆ Units available with Narrowband UVB, UVA or UVB lamps
- ◆ Built-in versatility makes localized treatment effortless
- ◆ Shipped fully assembled—ready for immediate use
- ◆ FREE insurance reimbursement assistance

CAUTION: Federal law restricts this device to sale by or on the order of a physician.

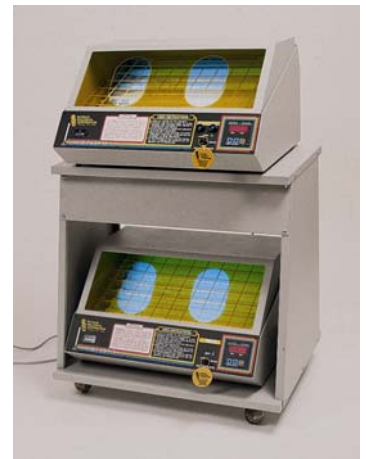

Two Hand/Foots units shown with optional cart

 **NATIONAL
BIOLOGICAL**

S.E.E. the Light!
Safe, Effective & Economical

—————→

Hand/Foot II™ Specifications

- ◆ Electronic digital timer
- ◆ Sturdy, protective lamp shield
- ◆ Full reflector backing to maximize UV output
- ◆ Ballasts designed for high UV output
- ◆ Ventilating fan—100 C.F.M.
- ◆ Includes Goggles and User's manual
- ◆ Dimensions

24"W x 20"D x 12-3/4"H

- ◆ Units

- ◆ UVB-NB - (8) 311nm NB-UVB Lamps (National Biological uses only new Philips TL Brand Narrowband UVB Lamps)
- ◆ UVA - (8) High Output UVA Lamps
- ◆ UVB - (8) High Output UVB Broadband Lamps

- ◆ Electrical

110-120V VAC 60 Hz

3.0 Amps with grounded plug



ETL LISTED
Conforms To
UL Std 2601-1
Certified to
ETL Testing Laboratories Inc.

- ◆ Shipping Weight—74 lbs.
(Actual Unit Weight—68 lbs.)



ISO 13485
Quality Certified



23700 Mercantile Road
Beachwood, OH 44122

(800) 338-5045 Fax: (216) 765-0271
Email: info@PhototherapyExperts.com
Web: www.PhototherapyExperts.com

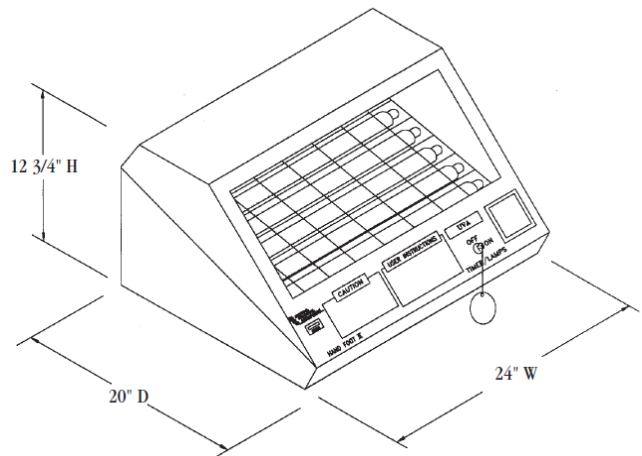

Unbeatable Service:

- ◆ Shipped fully assembled
- ◆ Unlimited customer support
- ◆ Three-year warranty (excluding lamps)
- ◆ Insurance reimbursable, in most cases, when purchased for home use and prescribed by a physician
- ◆ All major credit cards accepted
- ◆ Financing options available

Optional Hand/Foot Cart



The sturdy Hand/Foot Cart accommodates two Hand/Foot units at a comfortable height for patient treatment. Heavy duty casters make it easy to move the cart throughout the office.

29" W x 32" H x 17" D upper
21.5" D lower